

***P**rotection against Flooding*



Edition 01/1998

-
- floor drains backflow stops siphon lifts
 - submersible pumps volatile liquid trap
 - KESSEL stackable system
-

Contents

	Information about backflow and prevention of backflow Examples of situations and specimen applications	page 2 - 5
	Floor drains with backflow stop Floor drains with backflow stop and pump	page 6 - 7
	Backflow stops for sewages Backflow stops for stormwater	page 8 - 11
	Volatile liquid trap with backflow stop	page 10 - 11
	Siphon lifts for sewage Siphon lifts for waste water Submersible pumps	page 10 - 15
	KESSEL stackable system - underground installation	page 16



Avoid this happening!

1. What is a backflow?

After heavy rainfall the main sewer has not always enough capacity to handle the water quantity and to drain completely. The water level can then rise in parts of the main sewer, entry shafts, pipes connecting dwellings to the main sewer and in down pipes until the level of backflow, which is usually the height of the road surface.

2. What might happen?

All drains below this level risk backflow. Sewage can enter into the cellar leading to high damage to building and household effects. To pump out the sewage and repair damage is expensive and means a lot of work.

A landlord may be hold responsible for his tenants effects. Insurance can reduce or refuse to pay indemnities, if the ground drainage does not correspond to the regulations. No attempt at prevention can be very costly!

3. What is important?

You must always expect backflow and take sufficient precautions against backflow.

A distinction is made between storm water / waste water, which does not contain faeces and sewage which contains faeces (including sewage from WCs and urinals).

Sewage which exists below the backflow level and the public mains must be disposed of by means of a siphon lift. Sewage which occurs below backflow level but can be fed into the public main via a natural gradient should be transferred via a siphon or via backflow stops in accordance with the requirements of EN 12056-1 and EN 12056-4

Domestic waste water can be directly transferred to the main sewer when an adequate backflow stop is installed, for instance a floor gully with backflow stop for water not containing sewage.

When you want to transfer waste water during a backflow - e. g. water from the washing machine - a floor drain with integrated backflow stop is advisable.

Rainwater from small surfaces can percolate away, for instance rainwater from stairs to the groundlevel, when there are suitable thresholds at basement entrances or grooves at garage entrances, which can prevent flooding of rooms at groundlevel as long as the backflow stop is closed.

When toilets are installed in rooms at groundlevel, a backflow stop against sewage containing faeces has to be installed.

4. What do International Technical Specifications state?

Drains located below backflow level according to EN 12065-1 must be protected against backflow. Drains include floor gullies, hand-basins, washing machines, showers and so on. The backflow level is specified by the local authorities according to local criteria. If no specifications are available, the height of the road surface at the connecting point applies.

For rooms in zones which are not frequently used,

- a) **sewage containing faeces** can be led off via backflow stops acc. to DIN 19578, or
- b) **sewage not containing faeces** or components from urinals or WCs can be led off via backflow stops acc. to DIN 1997 if the drain points do not need to be used in the event of backflow.

Backflow stops acc. to DIN 1997 and DIN 19578 can be used if:

- no permanent water drainage is necessary (e.g. after separator systems),
- only a limited number of people uses the system (e.g. as in family houses) and a WC is available above the backflow level,
- it does not need to serve any considerable rain catchment area and flooding of low-lying rooms by water draining off small surfaces, for example cellar floors, garage entrances etc. is prevented by suitable means (e.g. sill, etc.).

Backflow stops must be inspected in accordance with construction regulations and must have a test symbol in accordance with DIN 1997 or DIN 19578.

Water occurring above the backflow level flows off according to the principle of communicating pipes in the event of backflow. However, if a backflow stop has been incorrectly installed and sewage from the building is thus led off above the backflow level because the backflow stop has closed as intended in the event of backflow, a cellar could become flooded when a bath wick is above the backflow level is emptied. It is moreover not possible to use a WC during this period.

5. Who can give you advice?

Protection against backflow is a specialist's business, not DIY. Ask your plumber, architect or building engineer.

6. Important advice

Like any technical device the drain with backflow stop has to be maintained and cleaned regularly and carefully. According to EN 12056 twice a year. This is the only way to guarantee continuous operation. Your plumber will advise you.

Methods of installing backflow stops

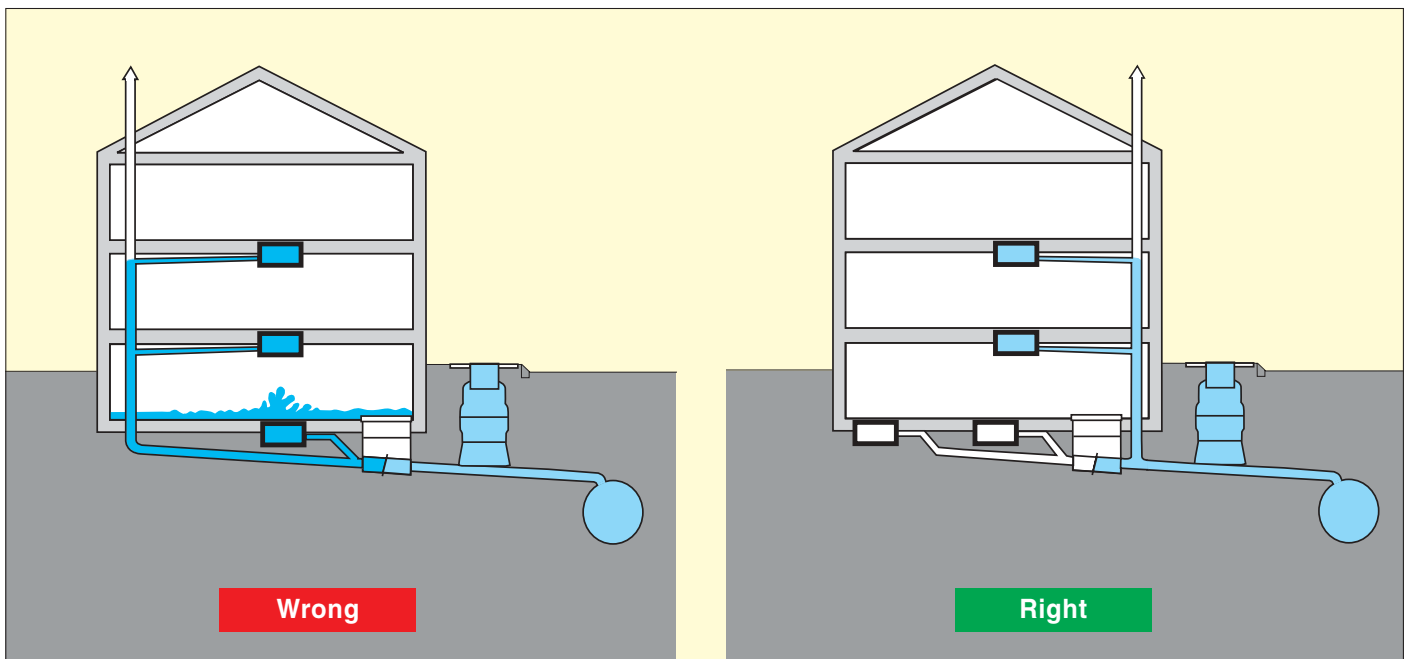

Only drains below the backflow level should be protected against backflow. Drains above the backflow level with a sufficient gradient can join the main sewer without a backflow stop.

Areas of application

<p>Example</p>	<p>1. Example: Groundfloor with drain</p> <p>You have a cellar with a single floor drain with a free gradient to the mains. As this drain is below backflow level, there is a danger of overload of the main drain and danger of flooding of the basement, for instance after heavy rainfall.</p>	<p>2. Example: Backflow in the groundfloor</p> <p>You want to transfer waste water despite the main drain is overcharged, for instance when there is flooding.</p>	<p>3. Example: Drain in the basement with closed pipe system</p> <p>You have in your cellar a wash-basin, a shower, a washing machine. As these drains are below backflow level, there is danger of overload of the main drain and danger of flooding of the basement, for instance after heavy rainfall.</p>
<p>Picture</p>			
<p>Water to drain</p>	<p>stormwater</p>	<p>waste water / stormwater</p>	<p>waste water</p>
<p>Drain</p>	<p>Below backflow level, pipe with free gradient to the main drains.</p>	<p>Below backflow level, pipe with free gradient to the main drains. The stormwater/ waste water is transferred to the main drain against the backflow.</p>	<p>Below backflow level, pipe with free gradient to the main drains.</p>
<p>Solution</p>	<p>KESSEL floor drain „The Universal“</p> <p>„The Universal“</p>	<p>KESSEL floor drain Pumpfix®</p> <p>Pumpfix®</p>	<p>KESSEL backflow stop Staufix® SWA</p> <p>Staufix® SWA</p>
<p>Page</p>	<p>6 / 7</p>	<p>6 / 7</p>	<p>10 / 11</p>

<p style="writing-mode: vertical-rl; transform: rotate(180deg);">Example</p>	<p>4. Example: Backflow in the cellar with toilet</p>	<p>5. Example: Drain for stormwater below level of the main drain</p>	<p>6. Example: Sewage below the level of the mains drains</p>
	<p>You have a toilet installed in the cellar. Sewage is transferred via a pipe with a free gradient to the mains. There is danger of overload of the main drain and danger of flooding of the cellar, for instance after heavy rainfall.</p>	<p>You want to install a wash-basin in the cellar, but the waste water can not be transferred to the main drain via a free gradient.</p>	<p>You have a toilet installed in your basement. But the main drains are at a higher level than your cellar.</p>
<p style="writing-mode: vertical-rl; transform: rotate(180deg);">picture</p>			
<p style="writing-mode: vertical-rl; transform: rotate(180deg);">water to drain</p>	<p>sewage</p>	<p>waste water</p>	<p>sewage</p>
<p style="writing-mode: vertical-rl; transform: rotate(180deg);">drain</p>	<p>Below backflow level, pipe with free gradient to the main drain.</p>	<p>Below the level of the main drain.</p>	<p>Below main drains level.</p>
<p style="writing-mode: vertical-rl; transform: rotate(180deg);">solution</p>	<p>KESSEL backflow stop Staufix® FKA</p> <p>Staufix® FKA</p>	<p>KESSEL siphon Aqualift® / Minilift</p> <p>Aqualift® Minilift</p>	<p>KESSEL siphon lifts for sewage</p> <p>WC grinder Siphon lift for sewage</p>
<p style="writing-mode: vertical-rl; transform: rotate(180deg);">Page</p>	<p>10 / 11</p>	<p>12 / 15</p>	<p>10 / 11</p>

Floor drains with backflowstop

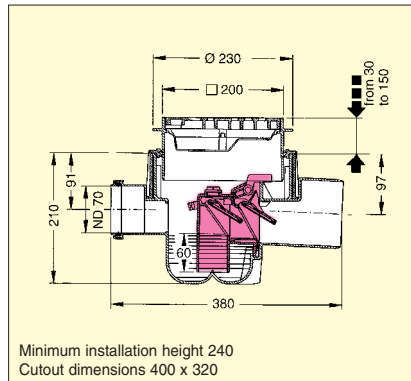

KESSEL "Universal" cellar drain, ND 100
With telescopic upper sections, height can be varied by up to 120 mm, 2 x ND 50 inlets and 1 x ND 70 inlet
 Version with slotted grid* 200 x 200 mm, polymer, **black**
 Version with slotted grid* 200 x 200 mm, **stainless steel**, screw-on
 Version with slotted grid* 200 x 200 mm, polymer, **stone grey**
 Side outlet, 2.5°, discharge rate 1.8 l/s
 With removable double backflow stop, 2 automatically-closing flaps, 1 with manually-operated emergency gate
 With integral odour trap, sludge basket, stopper

Ü KESSEL-GmbH
 DIN 1997/DIN 19599 Test symbol PA-I 4051

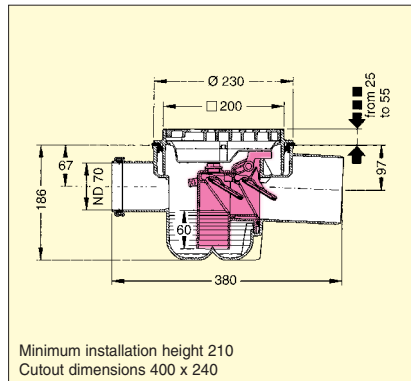

KESSEL "Universal" cellar drain, ND 100 and one ND 70 inlet
With one telescopic upper section, height can be varied by up to 30 mm
 Version with slotted grid* 200 x 200 mm, polymer, **black**
 Version with slotted grid* 200 x 200 mm, **stainless steel**, screw-on
 Version with slotted grid* 200 x 200 mm, polymer, **stone grey**
 Side outlet, 2.5°, discharge rate 1.8 l/s
 With removable double backflow stop, 2 automatically-closing flaps, 1 with manually-operated emergency gate
 With integral odour trap, sludge basket, stopper

Ü KESSEL-GmbH
 DIN 1997/DIN 19599 Test symbol PA-I 4051

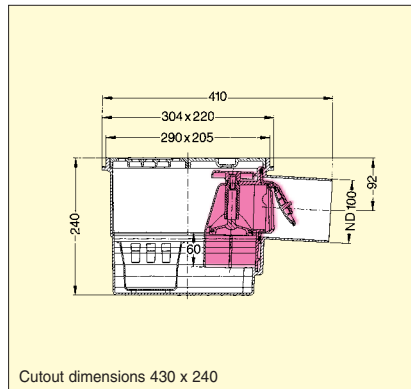

KESSEL Drehtfix cellar drain, PVC, ND 100 Size 2

Side outlet, 2.5°
 Discharge rate 1.8 l/s
 With removable double backflow stop
 With integral odour trap, sludge basket
 Slotted grid/cover plate, PVC, Class K3*
 One automatic sealing flap, one emergency manually locked closure
 With removable triple backflowstop and two automatic sealing flaps

Ü KESSEL-GmbH
 DIN 1997/DIN 19599 Test symbol PA-I 3089

Floor drains with backflow stop and pump

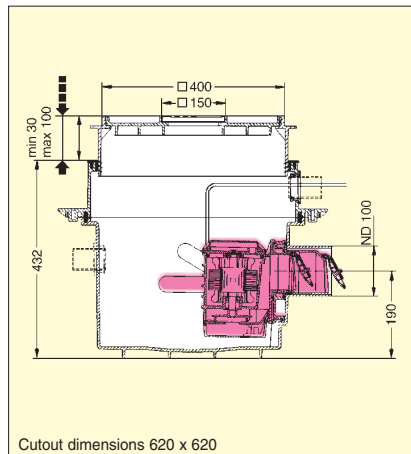

KESSEL floor drain „Pumpfix“ made from polymer, ND 100

For underground installation, installation depth 460 - 530 mm,
 Side outlet 2.5°, discharge rate 1.6 l/s
 With removable pump, double backflow stop and integral odour trap, slotted grid/cover plate to class A made from polymer, two automatic sealing flaps, one emergency manually locked closure, pump cuts in automatically if backflow occurs, suitable for waste water (no faeces!), not suitable for converting to siphon, height adaptable up to 70 mm, installation depth until 875 mm, weight about 20 kg

Ü KESSEL-GmbH
 DIN 1997/DIN 19599 Test symbol PA-I 3090

*K3 = max. load 300 kg

Nom. dia.	Order No.	Qty./carton	Qty./pallet
-----------	-----------	-------------	-------------

ND 100	27 610	1	32
ND 100	27 620	1	32
ND 100	27 630	1	32

KESSEL advantages:

- Upper sections can be rotated and tilted, telescopically height-adjustable
- Optimum pipe cleaning after removal of backflow stop
- Inlet in ND 50 and ND 70 as standard
- Can be extended and combined with additional components
- Leak-testing acc. to DIN in installed condition

ND 100	27 710	1	32
ND 100	27 720	1	32
ND 100	27 730	1	32

KESSEL advantages:

- Upper sections can be rotated and tilted, telescopically height-adjustable
- Optimum pipe cleaning after removal of backflow stop
- Can be extended and combined with additional components
- Leak-testing acc. to DIN in installed condition

ND 100	27 300	6	48
--------	--------	---	----

KESSEL advantages:

- Can be converted after installation to KESSEL *Drehfix* drain with triple backflow stop
- Optimum pipe cleaning after removal of backflow stop
- Level adjustment using upper sections **Size 2**
- Further connections possible with ND 50, 70 inlet stub pipes
- Can be extended and combined with additional components

Nom. dia	Order No.	Qty./carton	Qty./pallet
----------	-----------	-------------	-------------

ND 100	28 451	1	-
--------	--------	---	---

KESSEL advantages:

- Upper part tiltable, 360° turnable, stepless height-adjustable by 70 mm
- Protection against moisture by installation of a clamp sealing flange, please see page 16
- Accessible pipe cleaning after removal of pump
- Discharge waste water (no faeces!) against backflow pressure of up to 0.7 bar
- Connections with ND 50, 70, 100 inlet stub pipes can be fixed
- Additional components available

For prices ask your local plumber or dealer

Suggestions for installation KESSEL „Universal“ cellar drain

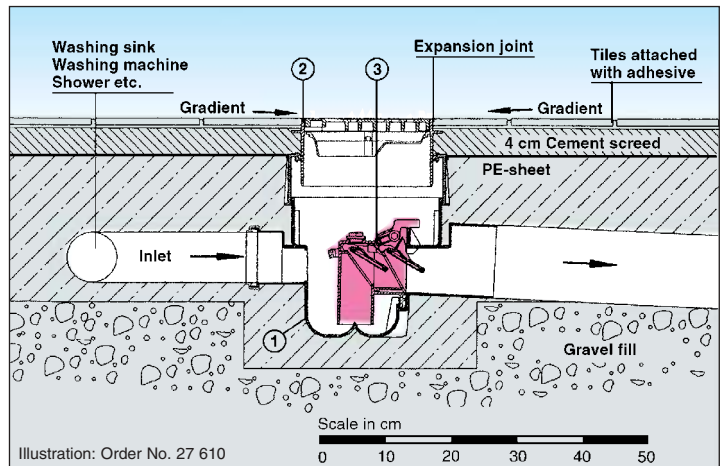

- ① KESSEL „Universal“ cellar drain body ③ Backflow flap
② Upper section

Installation and assembly hints

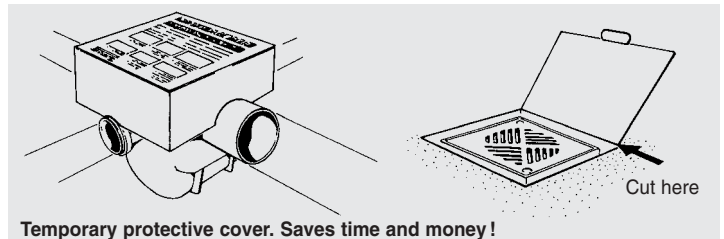

Suggestion for installation KESSEL-floor drain/cellar drain *Pumpfix*®

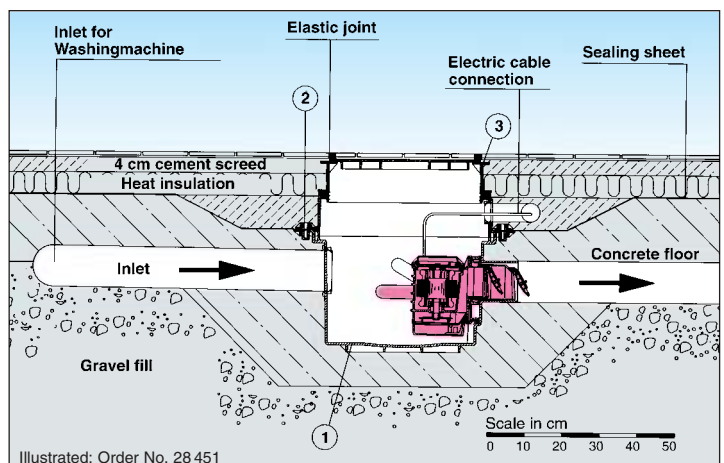

- ① Cellar drain *Pumpfix*® ③ Telescopic upper part
② Intermediate flange with PE-sheet

Installation and assembly hints

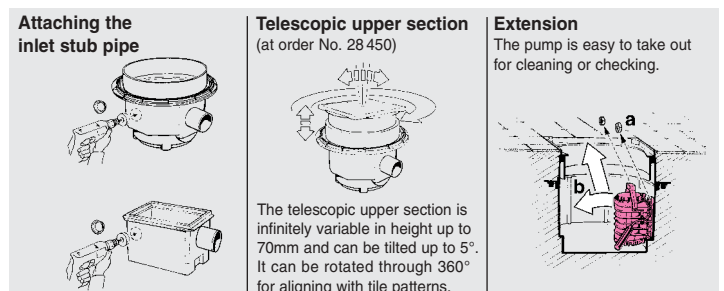

Backflow stops for continuous pipes for waste water

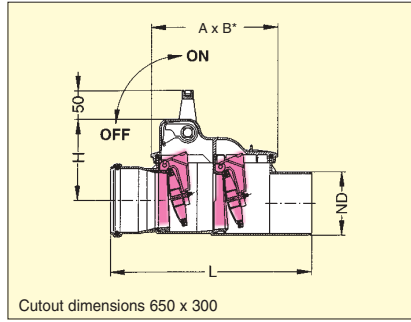

KESSEL Staufix® backflow stop, PVC, ND 100, 125, 150, 200

With two self-closing flaps (one for manual closure in an emergency)

ND 100	L = 355 mm	H = 140 mm + 60 mm
ND 125	L = 390 mm	H = 148 mm + 60 mm
ND 150	L = 460 mm	H = 165 mm + 60 mm
ND 200	L = 530 mm	H = 178 mm + 60 mm

U KESSEL-GmbH
DIN 1997

Test symbol PA-I 2782

*Dimensions see page 9

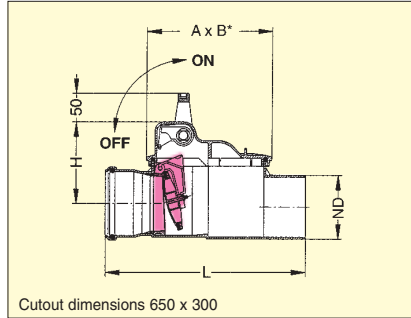

KESSEL Staufix® flood water shutoff valve, PVC, ND 100, 125, 150, 200

With self-closing flap also acting as manual closure in an emergency

ND 100	L = 355 mm	H = 140 mm + 60 mm
ND 125	L = 390 mm	H = 148 mm + 60 mm
ND 150	L = 460 mm	H = 165 mm + 60 mm
ND 200	L = 530 mm	H = 178 mm + 60 mm

*Dimensions see page 9

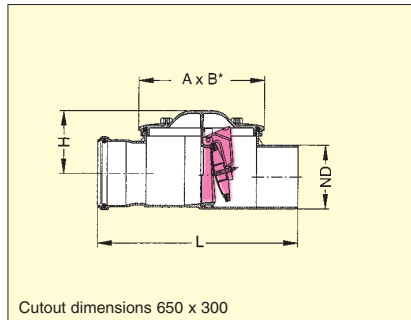

KESSEL Staufix® single-flap backflow stop PVC, ND 100, 125, 150, 200

With self-closing flap

ND 100	L = 355 mm	H = 110 mm
ND 125	L = 390 mm	H = 118 mm
ND 150	L = 460 mm	H = 135 mm
ND 200	L = 530 mm	H = 178 mm

*Dimensions see page 9

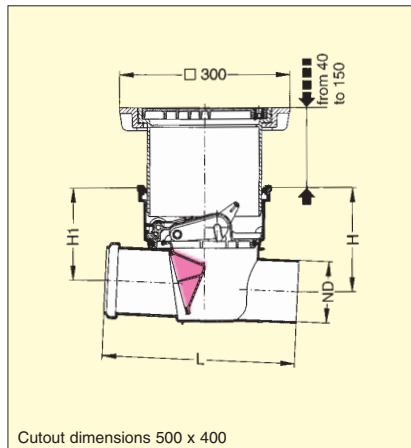

KESSEL Eurofix-Clausio® single-flap backflow stop, PVC, ND 100, 125, 150

With self-closing flap also acting as manual closure in an emergency

With upper section and cover plate, Class L15*, lockable (odour and surface water proof)

ND 100	L = 340 mm	H ₁ = 161 mm	H = 181 mm
ND 125	L = 340 mm	H ₁ = 161 mm	H = 181 mm
ND 150	L = 378 mm	H ₁ = 144 mm	H = 164 mm

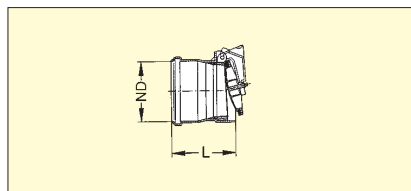

KESSEL pipe flap, PVC, ND 100, 125, 150, 200

With self-closing flap

DN	100	125	150	200
L	140	145	155	170

*L15 = max. load 1.5 metric tons

Nom. dia.	Order No.	Qty./carton	Qty./pallet
ND 100	73 100	1	50
ND 125	73 125	1	48
ND 150	73 150	1	30
ND 200	73 200	1	24

KESSEL advantages:

- Cover can be opened and inserts removed for optimum pipe cleaning

ND 100	72 100	1	50
ND 125	72 125	1	48
ND 150	72 150	1	30
ND 200	72 200	1	24

KESSEL advantages:

- Cover can be opened and flap removed for optimum pipe cleaning
- Can be upgraded to KESSEL backflow stop *Staufix*® acc. to DIN 1997

ND 100	71 100	1	50
ND 125	71 125	1	48
ND 150	71 150	1	30
ND 200	71 200	1	24

KESSEL advantages:

- Cover can be opened and flap and insert removed for optimum pipe cleaning
- Can be upgraded to KESSEL backflow stop *Staufix*® acc. to DIN 1997

ND 100	74 100.10	1	12
ND 125	74 125.10	1	12
ND 150	74 150.10	1	12

KESSEL advantages:

- Cover can be opened and flap removed for optimum pipe cleaning
- Cover plate can be locked
- Upper section can be turned and continuously varied in height by 100 mm
- Integral operating and maintenance shaft (expendable formwork)
- Max. load 1.5 t

ND 100	79 100	1	120
ND 125	79 125	1	120
ND 150	79 150	1	120
ND 200	79 200	1	120

For prices ask your local plumber or dealer

Specimen installation

For installation below the backflow for drainwater (not containing faeces)

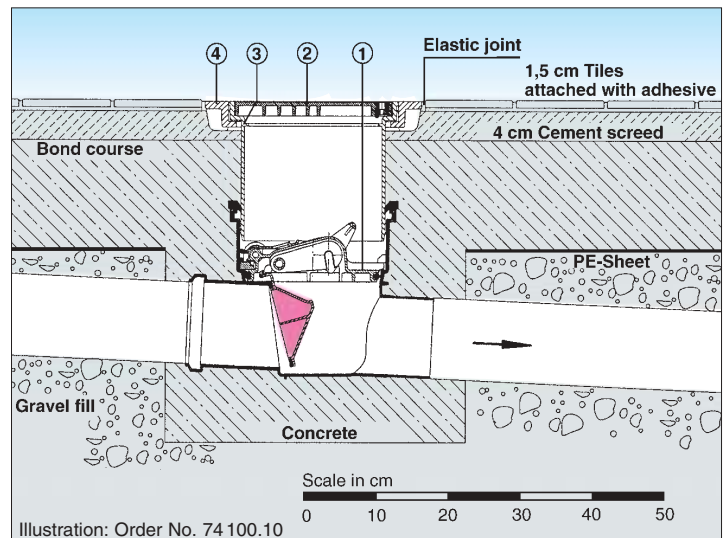

- ① KESSEL *Eurofix Clausio*® single flap backflow stop
- ② Cover plate, lockable (odour and surface water proof)
- ③ Upper section, PVC
- ④ Support frame, PVC

Installation and assembly hints *Eurofix Clausio*®

Cover mounting

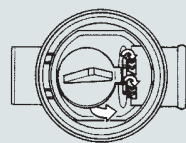

Check whether gate is located in guide



Coat cover seal with slip agent.
Move locking lever (black) and emergency lever (red) to position „AUF“ = „open“.

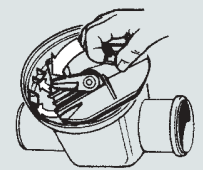

Insert the cover in holder with the arrows in the direction of flow and press down firmly.

ND	A x B
100	222 x 162
125	241 x 177
150	279 x 212
200	353 x 248

Backflow stops for sewage

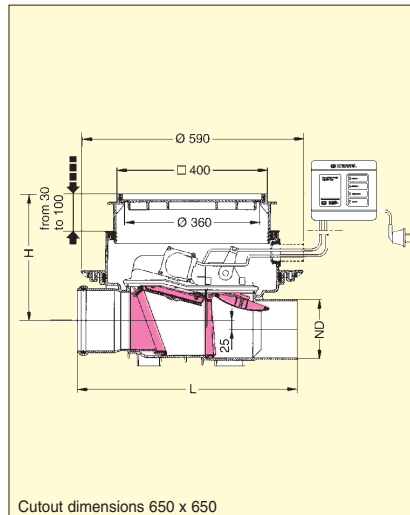

KESSEL Staufix® FKA automatic faeces backflow stop, polymer, ND 100, 125, 150

For underground installation at an installation depth of 370 - 440 mm

With telescopic upper part for stepless variable height and level equalisation, storm water proof covering plate, Cover class A15* polymer, automatic backflow stop with two open flaps. If backflow occurs, the FKA (regular operation) flap is closed and locked fully automatically, the second flap can be closed manually in an emergency. With switch and warning device and integral buffer battery. Protection type IP 30, motor protection type IP 67. Installation combination with cover plate in black or of choice surface as desired (Tiles can be fixed the covering plate). Weight approximately 17 kg

ND 100	L = 545 mm	H = 292 mm - 362 mm
ND 125	L = 555 mm	H = 285 mm - 355 mm
ND 150	L = 585 mm	H = 268 mm - 338 mm

U KESSEL-GmbH
DIN 19578



Test symbol PA-I 3664

Backflow stops for waste water / storm water

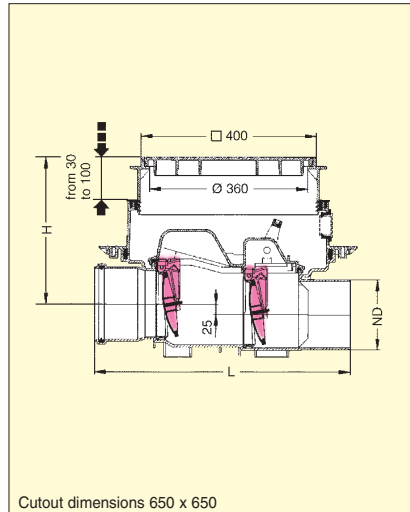

KESSEL backflow stop Staufix® SWA, polymer, ND 100, 125, 150

For underground installation at a depth of 370 - 440 mm.

With telescopic upper part for continuously variable height and level equalisation, polymer waterproof cover class A15*, backflow stop according to DIN 1997 with two self closing flaps, one of which can be operated manually in case of emergency.

Installation set with cover plate in black or choice surface as desired. (Tiles can be fixed the covering plate) Weight approximately 15 kg

ND 100	L = 545 mm	H = 292 mm - 362 mm
ND 125	L = 555 mm	H = 285 mm - 355 mm
ND 150	L = 585 mm	H = 268 mm - 338 mm

U KESSEL-GmbH
DIN 1997



Test symbol PA-I 3662

Volatile liquid trap with backflow stop

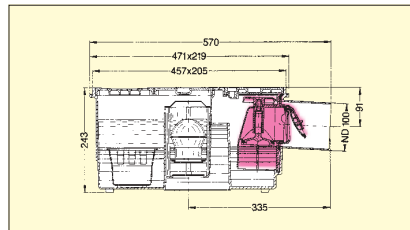

KESSEL volatile liquid trap with backflow stop, ABS, ND 100

With integral odour trap, sludge basket and plastic cover plates/slotted grid, Class K3 (max. load 300 kg)

Siphon sewage lift for drain containing faeces

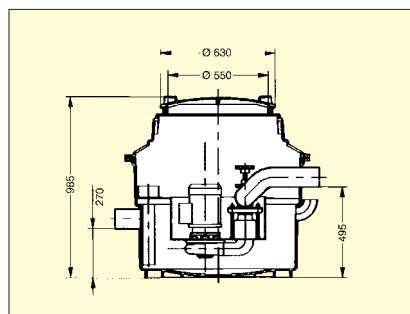

KESSEL siphon sewage lift. For installation above ground

Rated consumption 1,5 kW / discharge head 5 m
Rated consumption 2,2 kW / discharge head 10 m
For installation above ground, with odour tight cover for sewage containing faeces, with one cutting wheel pump, pressure pipe connection ND 80, pneumatic pressure switch-level control with contact alarm, 1 quick release non-return valve, protection IP 54, operating voltage 220/380 V, 50 Hz

U KESSEL-GmbH
DIN 1997

Test symbol PA-I 2782

*A 15 = max. load 1,5 to.

Nom. dia.	Order No.	Qty./carton	Qty./pallet
ND 100	83 100 S *	1	-
ND 125	83 125 S *	1	-
ND 150	83 150 S *	1	-
ND 100	83 100 X *	1	-
ND 125	83 125 X *	1	-
ND 150	83 150 X *	1	-

KESSEL advantages:

- Upper part can be rotated, tilted and continuously varied to a height of 70 mm
- Absolutely waterproof against water pressure through the installation of the pressure sealing flange, please see page 16
- Integral operating and maintenance shaft
- Cover can be opened and inserts removed for accessible pipe cleaning
- Continues to operate for up to 8 hours if power supply fails

* S = Installation set with black covering plate
 * X = Installation set with covering plate for tiles

Nom. dia.	Order No.	Qty./carton	Qty./pallet
ND 100	73 100.10S *	1	-
ND 125	73 125.10S *	1	-
ND 150	73 150.10S *	1	-
ND 100	73 100.10X *	1	-
ND 125	73 125.10X *	1	-
ND 150	73 150.10X *	1	-

KESSEL advantages:

- Upper part can be rotated, tilted, and is continuously varied to a height adjustment of 70 mm
- Absolutely waterproof against water pressure through the installation of the pressure sealing flange, please see page 16
- Integral operating and maintenance shaft
- Cover can be opened and flap removed for accessible pipe cleaning
- This backflow stop can be retrofitted to the FKA automatic backflow stop for sewage containing faeces

* S = Installation set with black covering plate
 * X = Installation set with covering plate for tiles

Nom. dia.	Order No.	Qty./carton	Qty./pallet
ND 100	52 100	1	28

KESSEL advantages:

- Level equalization with upper sections order No. 52500, 32200
- Weight 3,0 kg
- Accessible pipe cleaning facility

Nom. dia.	Order No.	Qty./carton	Qty./pallet
ND 80	28 630	1	-
ND 80	28 635	1	-

KESSEL advantages:

- Fully automatic pressure switch-level control self-aerating, the running time of the pump is electronically controled
- Alarm given when electronic or thermic disturbance occurs
- Further inlets can be installed by drilling through the lateral sides
- Volume of the container about 150 l
- Weight around 85 kg

For prices ask your local plumber or dealer

Specimen installation (sewage containing faeces)

For installation below the backflow for drainwater (not containing faeces)

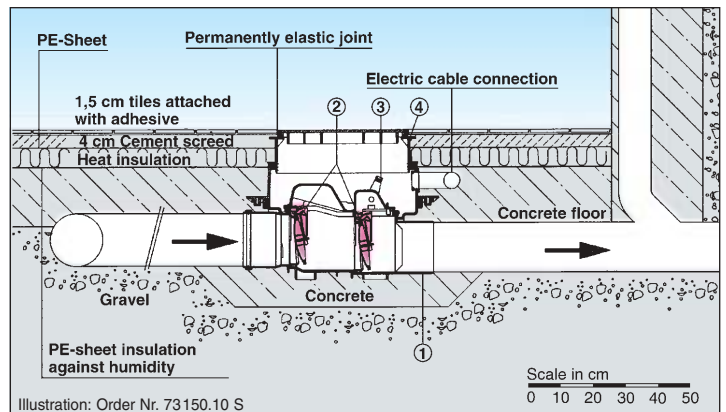

- Illustration: Order Nr. 73150.10 S
- ① SWA Backflow stop
 - ② Two automatically closing flaps
 - ③ Emergency closure
 - ④ Upper section with cover plates, Class A15, polymer

Installation and assembly hints

Removal, cleaning, installation

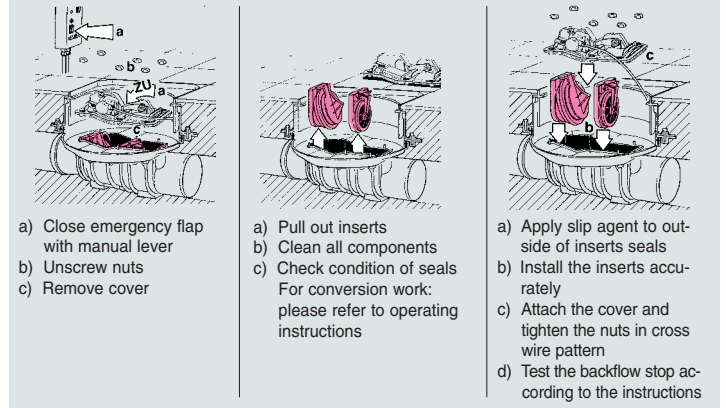

Specimen installation

For installation below the backflow

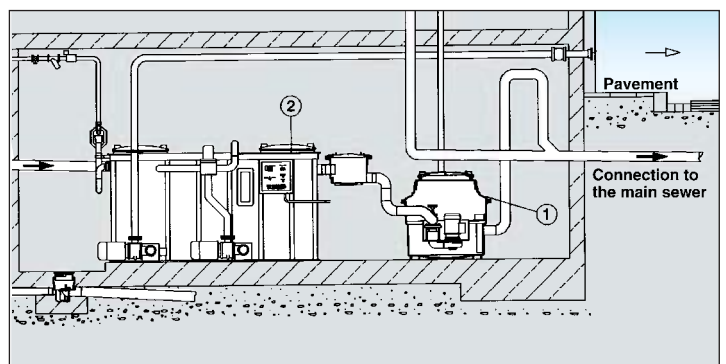

- ① KESSEL siphon sewage lift for installation above ground...
- ② ...installed behind a KESSEL grease separator

Performance graph of siphon lifts for sewage

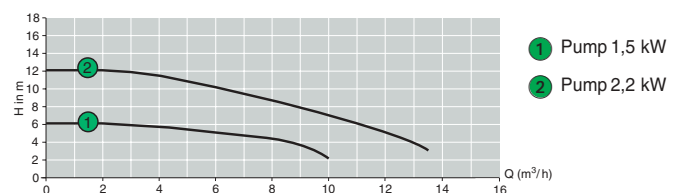

Siphon lifts for waste water / stormwater

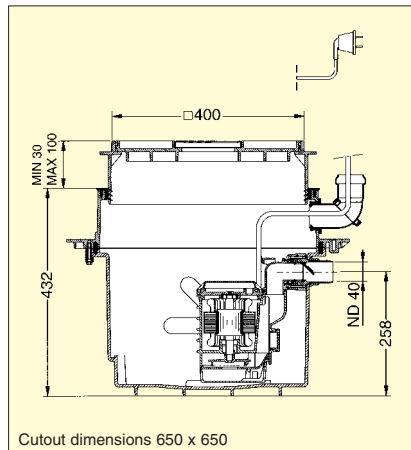

Cutout dimensions 650 x 650

KESSEL waste water siphon *Aqualift*® made from polymers for underground installation for waste water

for installation in the ground, installation depth 460 - 530 mm with telescopic upper part steplessly adjustable in height, rotatable and with angular adjustment; slotted grid made of polymers class A15, black, with sealing flange for insulation against humidity, with detachable pump, control by a float, integrated backflow flap, pressure connection R 1 1/2" outside diameter or Ø 40 mm, discharge head max. 10 m, operating voltage 230V-50Hz, rated consumption 0.5 kW, electric cable 5 m, weight approximately 19 kg

Ü KESSEL-GmbH
DIN 19761



Test symbol PA-I 3012

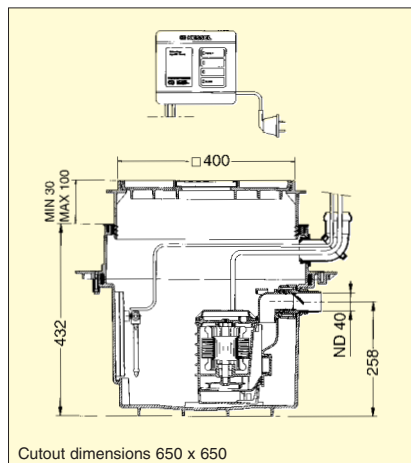
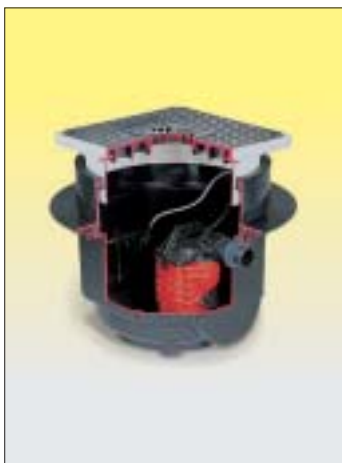

Cutout dimensions 650 x 650

KESSEL waste water siphon *Aqualift Tronic*® made from polymers for underground installation, for waste water

for installation in the ground, installation depth 460 - 530 mm with telescopic upper part steplessly adjustable in height, rotatable and with angular adjustment; slotted grid made from polymers class A15, black, with sealing flange for insulation against humidity, with detachable pump, controlled by a probe, integrated backflow flap, pressure connection R 1 1/2" outside diameter or Ø 40 mm, discharge head max. 10 m, operating voltage 230 V-50 Hz, rated consumption 0.5 kW, electric cable 5 m, weight approximately 19 kg

Ü KESSEL-GmbH
DIN 19761



Test symbol PA-I 3012

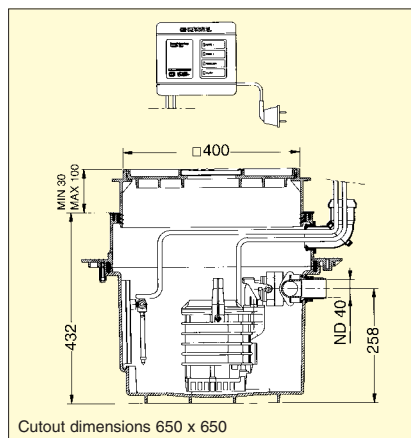

Cutout dimensions 650 x 650

KESSEL waste water siphon *Aqualift Duo*® made of polymers for underground installation, for waste water

for installation in the ground, installation depth 460 - 530 mm with telescopic upper part steplessly adjustable in height, rotatable and with angular adjustment; slotted grid made of polymers class A15, black, with sealing flange for insulation against humidity, with 2 detachable pumps, controlled by a probe, integrated backflow flap, pressure connection R 1 1/2" outside diameter or Ø 40 mm, discharge head max. 10 m, operating voltage 230 V, 50 Hz, rated consumption 2 x 0.5 kW, electric cable 5 m, weight approximately 26 kg

Ü KESSEL-GmbH
DIN 19761



Test symbol PA-I 3012

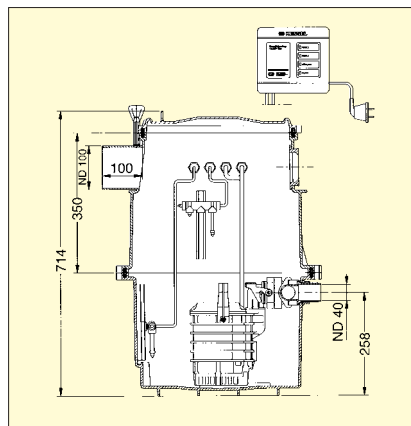

KESSEL double siphon lift for waste water made from PE-HD for installation above ground.

with 2 detachable pumps, with integrated backflow flap, controlled by an adjustable probe, inlet ND 100, aeration connection ND 70 (including seal for pipe) Pressure connection R 1 1/2" outside dia. or pressure pipe Ø 40 mm, height of inlet: 530 mm; total height 720 mm, Ø 450 mm, operating voltage; 230 V, 50 Hz; volume of container: max. 55 l, discharge head max. 10 m, operating voltage 230 V, 50 Hz, rated consumption 2 x 0.5 kW, electric cable 5 m, weight approximately 25 kg

Ü KESSEL-GmbH
DIN 19761



Test symbol PA-I 3012

Nom dia. Order No. Qty./carton Qty./pallet

ND 40 28 500 1 -

KESSEL advantages:

- Upper section can be rotated, tilted and is adjustable to a height of 70 mm
- Absolutely waterproof against water pressure due to the installation of the pressure sealing flange, please see page 16
- Integral, waterproof operation and maintenance shaft
- Connection of other inlets possible by drilling through the side panels
- With warning devices and adjustable control level

ND 40 28 550 1 -

KESSEL advantages:

- Upper section can be rotated, tilted and is adjustable to a height of 70 mm
- Absolutely waterproof against water pressure due to the installation of the pressure sealing flange, please see page 16
- Integral, waterproof operation and maintenance shaft
- Connection of other inlets possible by drilling through the side panels
- With warning devices and adjustable control level

ND 40 28 530 1 -

KESSEL advantages:

- Upper section can be rotated, tilted and is adjustable to a height of 70 mm
- Absolutely waterproof against water pressure due to the installation of the pressure sealing flange, please see page 16
- Integral, waterproof operation and maintenance shaft
- Connection of other inlets possible by drilling through the side panels
- With warning devices and adjustable control level
- Low wear, because the two pumps alternate in operation
- Through the bringing together of the pressure pipes a higher pumping rate is achieved for the stronger waste water flow through the automatic switch on of the second pump

ND 40 28 541 1 -

KESSEL advantages:

- Connection of other inlets possible through drilling the side wall
- With warning device and adjustable control level
- Low wear, because the two pumps alternate in operation
- Through the bringing together of the pressure pipes a higher pumping rate is achieved for the stronger waste water flow through the automatic switch on of the second pump
- Application: especially suitable as a siphon lift after a grease separator

Suggestions for installation

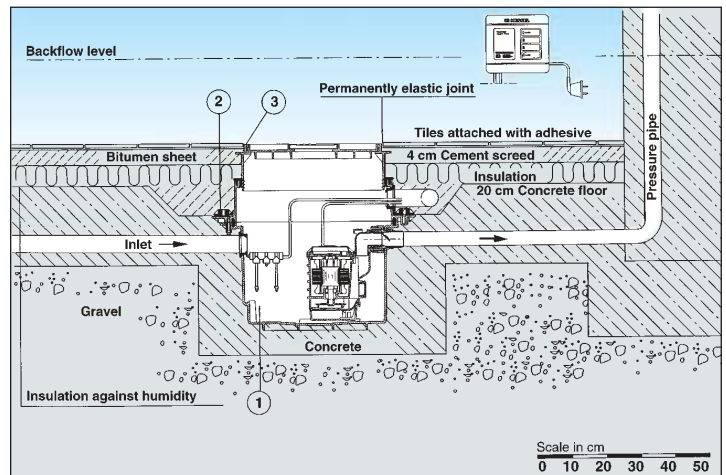

- ① KESSEL waste water siphon *Aqualift tronic*® ③ Telescopic upper part
② Pressure sealing flange

Performance graph *Aqualift*® pump

Discharge quantity Q (m ³ /h)	0,0	1,1	2,2	3,3	4,3	5,2	6,1	6,9	7,7	8,4	9,1
Discharge head H (mWS)	9,8	9,0	8,0	7,0	6,0	5,0	4,0	3,0	2,0	1,0	0,0

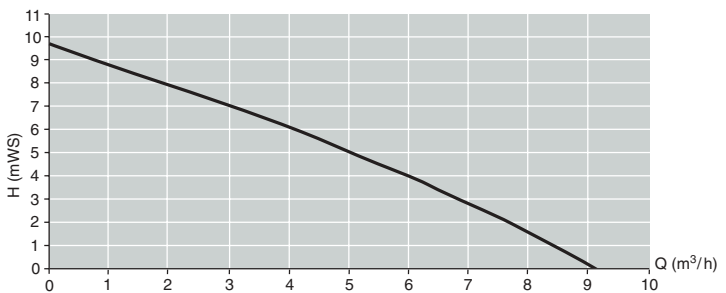

Power supply	Voltage	Nominal current	Power rating P1 / P2	Running speed	Motor protection	Plug
Alternating Current	230 V	2,12 A	480 W / 320 W	2800 min ⁻¹	is integrated in the motor	2-pin earthed 5 m cable

Installation and assembly hints

Connection of further inlets

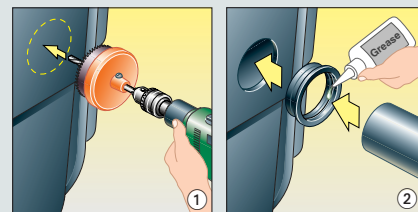

- ① Side inlets are fitted by drilling open the inspection chamber with Kessel circular cutter order no. 50 100
- ② Insert the seal ring corresponding to the pipe diameter, insert the pipe

Telescopic upper section

The telescopic upper part allows infinitely variable height up to 70 mm. The upper part can be tilted by 5°. To make the outlook fit to the floor pattern the telescopic upper part can be turned by 360°.

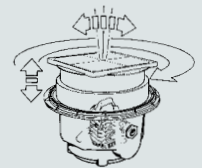

Siphon lifts for waste water

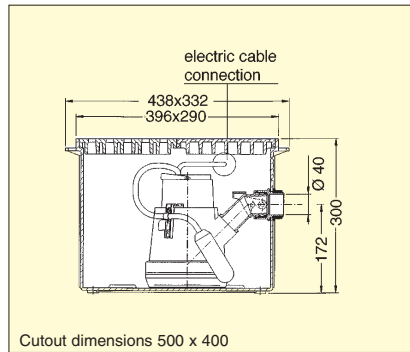
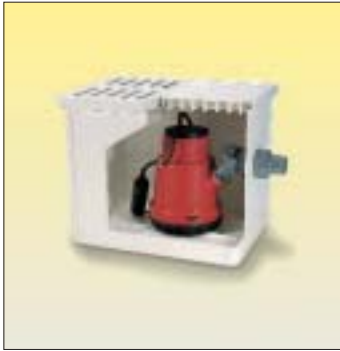

KESSEL waste water siphon *Minilift*, made from polymers for underground installation

Connection to delivery main R 1 1/2" outside dia. or pressure pipe ND 40 mm
 With removable pump, integral backstop flaps as well as slotted grid and cover plate class L 15.
 Use: for waste water (not containing faeces!)
 Head discharge: 6.5 metres, electric cable 5 m,
 operating voltage 220 V-50 Hz,
 Rated consumption: 0.3 kW, I = 1.6 Amp

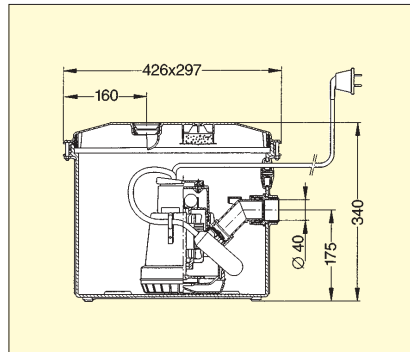

KESSEL waste water siphon *Minilift*, made from ABS for installation above floor level

Connection to delivery main R 1 1/2" outside dia. or pressure pipe ND 40 mm
 With removable pump, integral backstop flap.
 Use: for waste water (not containing faeces!)
 Head discharge: 6.5 metres, operating voltage 220 V-50 Hz
 rated consumption: 0.3 kW, I = 1.6 Amp



Submersible pumps

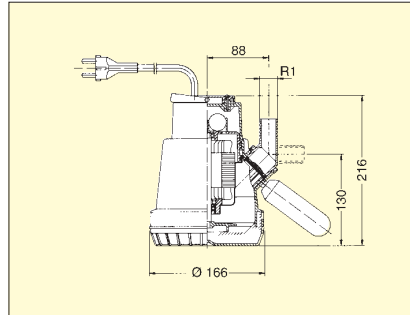

KESSEL submersible pump *KTP 300*, made from PP

with backflow stop, pipe connection can be turned,
 power rating: P1 = 300 W
 operating voltage: 230 V-50 Hz
 max. discharge head: 6,5 m
 max. discharge quantity: 8,7 m³/h
 Max. diving depth: 10 m
 Pressure pipe connection: R1" vertical/horizontal
 Suction plate can be taken off - lowering of the water level is possible to 8 mm
 10 m cable **without** floater R1 order no. **28 740**
 10 m cable **with** floater R1 order no. **28 840**

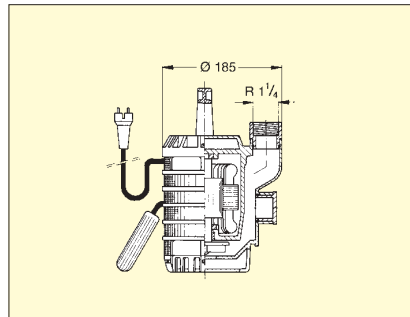

KESSEL submersible pump *DUOfix KTP 500*, made from PPO

pipe connection vertical/horizontal
 power rating: 500 W
 operating voltage: 230 V-50 Hz
 max. discharge head: 10,3 m
 max. discharge quantity: 9,5 m³/h
 Max. diving depth: 10 m
 Pressure pipe connection: R 1 1/4" vertical/horizontal
 10 m cable **without** floater R 1 1/4" order no. **28 710**
 10 m cable **with** floater R 1 1/4" order no. **28 810**

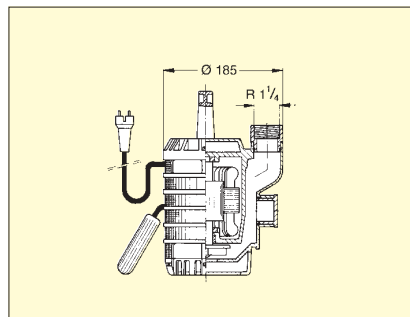

KESSEL submersible pump *DUOfix KTP 500 TITAN*, made from PPO

Pipe connection vertical/horizontal
 Pressure pipe connection: R 1 1/4" vertical/horizontal
 The *DUOfix KTP 500 TITAN* is suitable for water containing mechanical and chemical components
 It is not suitable for nitroethylene and trichlorethylene!
 Power rating: 500 W, operating voltage: 230 V-50 Hz
 max. discharge head: 10,3 m
 max. discharge quantity: 9,5 m³/h
 max. diving depth: 10 m
 10 m cable **with** floater R 1 1/4" order no. **28 850**

Nom. dia. Order No. Qty./carton Qty./pallet

ND 40 28 570 1 12

KESSEL advantages:

- No additional ventilation pipe necessary
- Can be matched to floor level size 3
- Can be connected to ND 50, 70, 100 inlet stub pipe
- Load capacity up to 1.5 tonnes
- Weight 7.2 kg
- Can be extended and combined with additional components
- Quick release pump fixing to facilitate mobile use of pump

ND 40 28 560 1 12

KESSEL advantages:

- ND 40 inlet as standard
- Can be connected to ND 50, 70, 100 inlet stub pipe
- Quick release pump fixing to facilitate mobile use of pump
- Weight 7.2 kg

Nom. dia Order No. Qty./carton Qty./pallet

R 1 28 740 1 48

R 1 28 840 1 48

KESSEL advantages:

- Mobile or steady use
- Low suction as of 8 mm is possible
- No tipping up, no lurching
- Can be fully overflowed

R 1 1/4 28 710 1 48

R 1 1/4 28 810 1 48

KESSEL advantages:

- Mobile or steady use
- Pressure pipe connection: vertical/horizontal
- Low suction as of 8 mm is possible
- No tipping up, no lurching
- Can be fully overflowed

R 1 1/4 28 850 1 48

KESSEL advantages:

- Resists chloring containing liquids (e.g. sea water)
- Corrosion resisting
- Mobile or steady use
- Pressure pipe connection: vertical/horizontal
- Low suction as of 8 mm is possible
- No tipping up, no lurching
- Can be fully overflowed

For prices ask your local plumber or dealer

Specimen installation

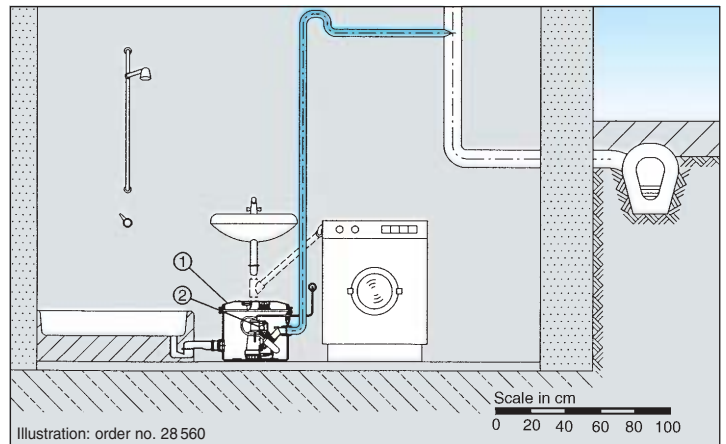

① KESSEL waste water siphon *Minilift* ② KESSEL *Minilift* pump

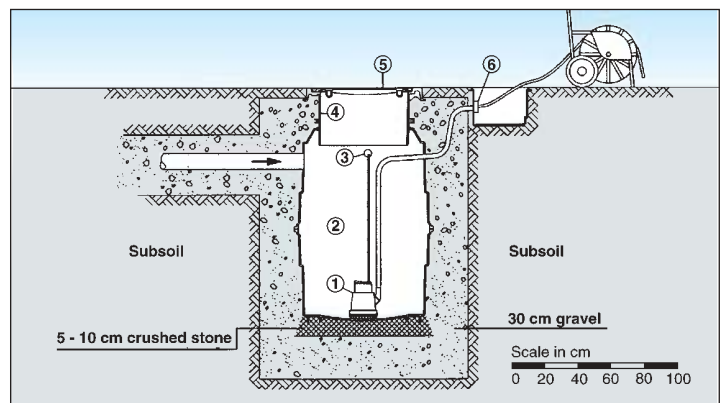

① KESSEL submersible pump ③ Cable connection ⑤ Cover of inspection chamber
 ② KESSEL Inspection chamber ④ KESSEL telescopic upper part ⑥ Pipe connection

Performance graph *KTP 300*

Discharge quantity Q (m ³ /h)	0,0	0,6	2,7	4,4	5,7	6,7	7,3	7,6
Discharge head H (mWS)	6,2	6,0	5,0	4,0	3,0	2,0	1,0	0,0

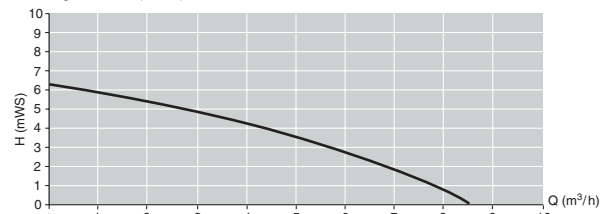

KTP 300	Power supply	Voltage	Nominal	Power rating P1 / P2	Running speed	Motor protection	Plug
	Alternating Current	230 V	current 1,27 A	280 W / 114 W	2800 min ⁻¹	is integrated in the motor	2-pin earthed

Performance graph *KTP 500* (with pressure pipe connection ND 32)

Discharge quantity Q (m ³ /h)	0,0	1,1	2,2	3,3	4,3	5,2	6,1	6,9	7,7	8,4	9,1
Discharge head H (mWS)	9,8	9	8	7	6	5	4	3	2	1	0

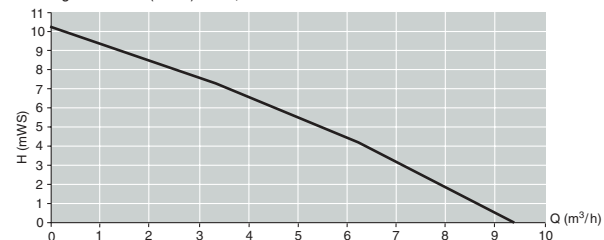

KTP 500	Power supply	Voltage	Nominal	Power rating P1 / P2	Running speed	Motor protection	Plug
	Alternating Current	230 V	current 2,1 A	480 W / 320 W	2800 min ⁻¹	is integrated in the motor	2-pin earthed

KESSEL stackable system - underground installation

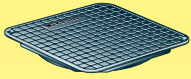

Lid class A (max. load 1,5 tons)
made from polymer
black
order no. **83 050**

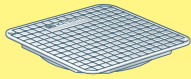

Lid class A (max. load 1,5 tons)
made from polymer
stone grey
order no. **83 051**



Lid class A (max. load 1,5 tons)
made from polymer
for tiles
order no. **83 052**



Telescopic upper part

stone grey, size 120
stepless height adjustable up to 70 mm
order no. **83 060**

stone grey, size 220
stepless height adjustable up to 180 mm
order no. **83 061**



extension tube, (H = 180 mm) sealing ring included
order no. **83 070**



flange made from polymer, screws included
order no. **83 018**



foil for protection against humidity made from natural caoutchuc/Sterol Butadiene rubber
order no. **83 019**

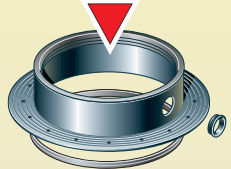

flange including seal 450 and screw connection
order no. **83 020**

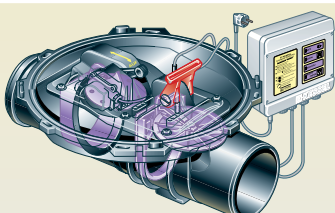

base element complete assembled for KESSEL - backflow stop Staufix® FKA
ND 100 order no. **83 002**
ND 125 order no. **83 003**
ND 150 order no. **83 004**
cutout dimensions 650 x 650 mm

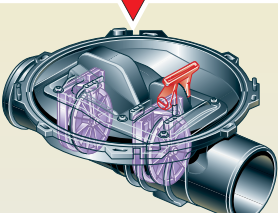

base element complete assembled for KESSEL - backflow stop Staufix® SWA
ND 100 order no. **73 002**
ND 125 order no. **73 003**
ND 150 order no. **73 004**
cutout dimensions 650 x 650 mm

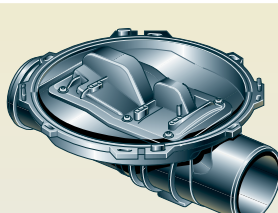

base element complete assembled for KESSEL - base element/cleaning pipe Staufix® SWA / FKA
ND 100 order no. **80 002**
ND 125 order no. **80 003**
ND 150 order no. **80 004**
cutout dimensions 650 x 650 mm



KESSEL
Everything for drainage

Bahnhofstraße 31 · D-85101 Lenting
Telephone (+)8456/27-184 or 27-195
Telefax (+)8456/27-188
<http://www.kessel.de>

Everything for drainage

- Backflow stops, cleaning pipes, drains made from polymers and cast iron, volatile liquid traps
- Siphons, pumps, warning and switching devices
- Separators
- Inspection chambers
- Special receptables and shafts made to order
- Fittings
- Stainless steel
- Rainwater management systems

Your distributor: